

Vibration Hour Meter FOR ANY VIBRATING EQUIPMENT with service alert for oilchange & lubrication + transport filter

Surface Mount
Series N151
Model Code N151 0101 0180 0003



IMD Europe GmbH · Auf dem Molzberg 2 · D-57548 Kirchen

Quality Features

-  Absolut dust-, fresh-, & saltwater resistant till 20m underwatersurface.
-  The Flash Alert service displays reminders for preventive maintenance.
-  Due to a self-contained battery it has a life cycle of 12 years.
-  Extrem shock proof up to at least 55G (depending on the product the manage up to 90G)
-  High contrast LCD display is always lit and is polarized to prevent discoloration from UV exposure.
-  Pressure washer cleaning possible.

Product Pictures

Top View



Perspective View



Mechanical Specification

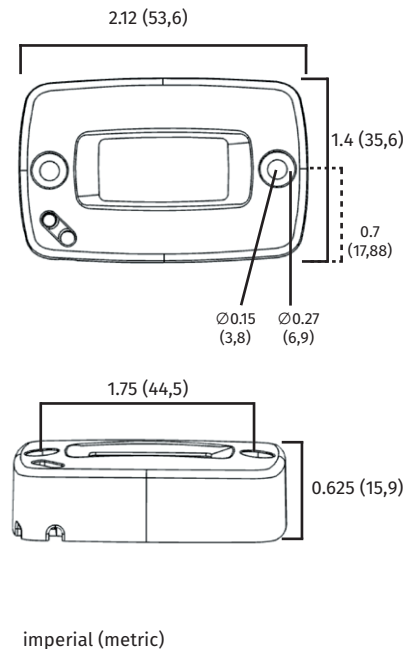

OEM and Packaging

Blister Card Design Pack.
All hardware included.

- Hour Meter
- Screws
- Manual
- Double sided tape



Apply for

For any equipment with regular vibration.

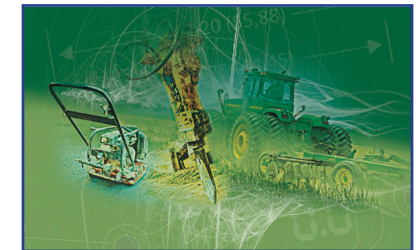

Transport Filter



During the first sec. after start of the engine it will check out if there is a constant frequency. Therefore the meter adds detecting sec. behind time to determine the real operating hours. Does not count when random vibration applies.

Instruction

Activation: Keep the menu button pressed until the code number is replaced by 0000.0.
Event counter: Hold down the menu button for 10 sec. The displayed number is the number of on / off events.



Integrated Functions

for N151 0101 0180 0003
Hours

Flash Alerts:
Oil Change (100h) Warning for 1h
Lubrication (25h) Warning for 1h

With Transport Filter
With Event Counter